

HOW TO ASSESS DAMAGE TO YOUR FRAME IN ACCORDANCE WITH THE EN15635 STANDARD ?

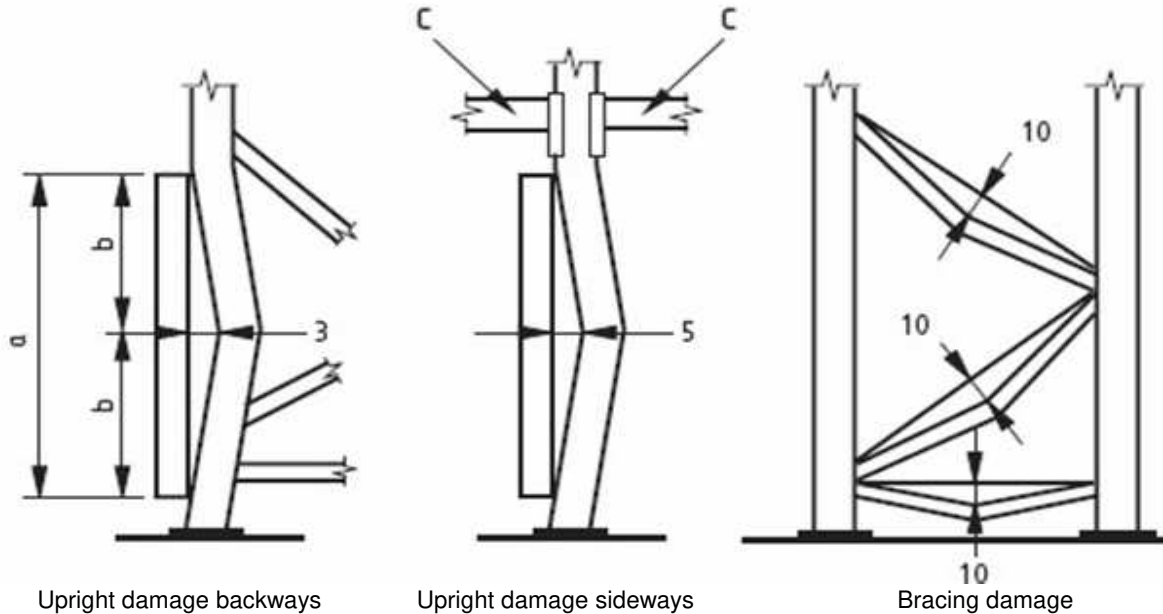

RISK ASSESSMENT & DAMAGE LEVELS

Green level

- Damage is inferior to the limits below.
- A continuous & regular surveillance is required.
- A higher level than the green level is a risk.

Orange Level

- Damage does not exceed more than twice the limits below.
- Immediate unloading is not required but once unloaded repairs have to be made before re-loading.
- If not unloaded within 4 weeks unloading & repairs become compulsory & the area has to be secured.

Red level

- Damage exceeds twice or more the limits below.
- Immediate unloading is compulsory.
- The area must be secured.

a ruler of 1000 mm

b mid-distance of the ruler

c beams

Measuring the damage to an upright and/or spare leg has to be done this way :

Damage to the front of the upright (i.e. damage backways of the upright) :

- A straight ruler is put on the plane surface of the damaged side of the upright with the damage center in the center of the ruler.
- Maximum deflection of the damaged area should not exceed 3 mm under the 1000 mm ruler.

Damage to the side of the upright (i.e sideways damage) :

- A straight ruler is put on the plane surface of the damaged side of the upright with the damage center in the center of the ruler.
- Maximum deflection of the damaged area should not exceed 5 mm under the 1000 mm ruler.

Damage to the front and to the side of the upright (i.e. backways & sideways damage) :

- A straight ruler is put on the plane surface of the damaged sides of the upright with the damage center in the center of the ruler.
- Maximum deflection of the damaged area should not exceed 3 mm backways and 5 mm sideways under the 1000 mm ruler.

Damage to the bracing :

- A straight ruler is put on the plane surface of the damaged side of the bracing with the damage center in the center of the ruler.
- Maximum deflection of the damaged area should not exceed 10 mm in any direction under the 1000 mm ruler.
- If a 1000 mm ruler is not convenient damage should be calculated pro rata. (E.g. 5 mm under a 500 mm ruler)

DO NOT

- * try to straighten braces or uprights.
- * weld braces or uprights
- * weld reinforcements to braces or uprights.
- * use second hand items.

REPLACE

only with original parts obtained from the manufacturer.

REPAIRS

should be done by the manufacturer or at least under his supervision.

WARNING

Uprights & braces that have been torn, twisted or cracked have to be replaced immediately and completely.